

SCALE 比例: N/A

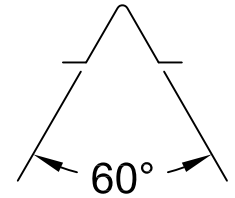
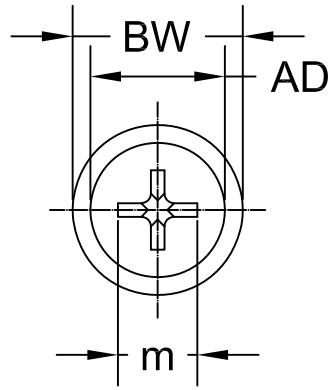
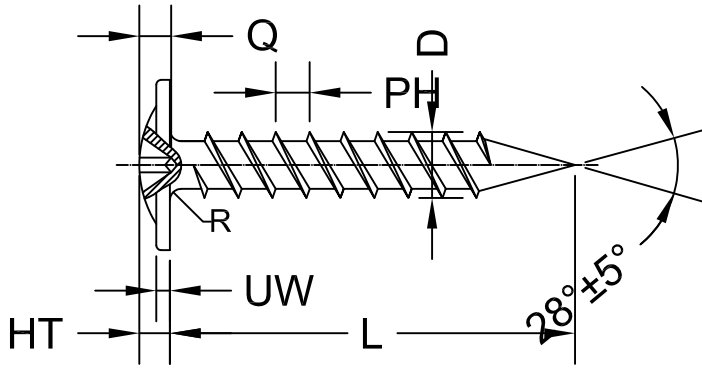

Nominal Diameter		4.20
D		4.12-4.27
AD		6.80-7.20
BW		10.40-11.00
UW		1.40-1.78
HT		2.55-2.85
R ref.		1.00
PH ref.		1.69
Phillips Recess	Recess No.	#2
	m ref.	4.70
	Q	2.14-2.64

Nominal L	13	16	19	22	25	32
min.	12.20	15.20	18.20	21.20	24.00	31.00
max.	13.80	16.80	19.80	22.80	26.00	33.00

Note:

- Material : C1022
- Surface finish: Zinc & Clear Cr6
- Core Hardness: 380HV-450HV
- Case Hardness: 550HV-800HV
- Inspection: (1) For dimension, AQL=1.0, n=80, Ac=2
(2) For Mechanical characteristics and surface integrity:
Non-destructive test: AQL=0.65, n=8, Ac=0
Destructive Test: AQL=1.5, n=3, Ac=0

修订次序	修订日期	修订内容
1	2009-9-23	根据HY新制作图纸。
2		
3		
4		

Phillips Recess Wafer Head (button Head) Fine Thread Needle Point

SIZE 尺寸:
Various

DWG NO. 图纸号: QE-FM-0151	CUSTOMER DWG NO. 客户图纸号: N/A	CONTRACT No. 合同号/ORDER No. 订单号: PFPL-FD090207	FINISH 表面处理: Zinc & Clear Cr6	MATERIAL 材料: C1022
----------------------------	--------------------------------	--	----------------------------------	-----------------------

 <p>Qingdao East West International Trading</p>	DRAWN BY 制图: Simon	APPROVE BY 审核:	UNITS 图纸单位: mm
	DATE 日期: 2009-9-23		Sheet 页数: 1/1