

SCALE 比例: N/A

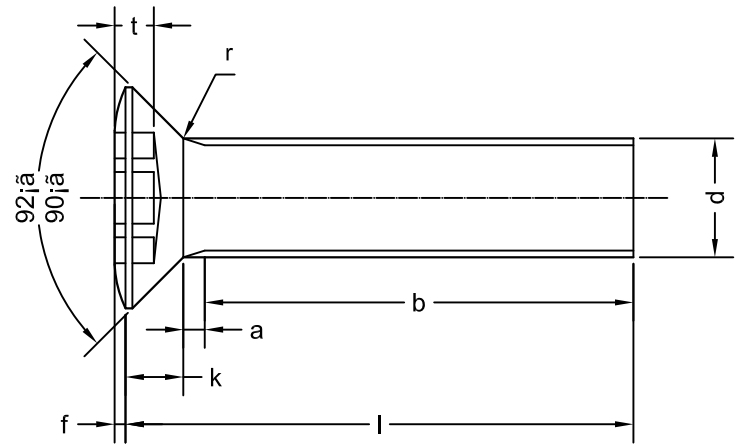
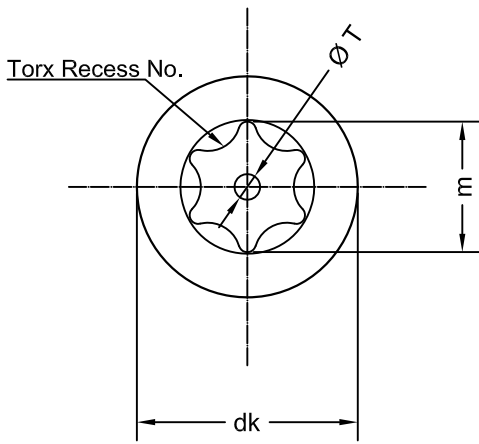

Thread Size (d)	P	a (max)	b	dk	f _≈	k (max)	r (max)	Torx Recess No.	m ≈	t (min)	ØT
M3.5	0.60	1.20	Full thread	6.50-6.14	0.90	1.93	0.35	T-20	3.94	1.27	1.00

Note:

1. Material: C1006-C1008
2. Surface coating finish: As required in order.
3. Thread end: To meet DIN 78-Ko
4. Thread Class: To fit 6h gauge after plating.
5. Mechanical proprieties: Grade 4.8 to meet EN ISO 898-1 : 2001
6. Tolerance of Legth(l): To meet DIN 964:1990
7. Inspection: To meet ISO 3269:2000

修订次序	修订日期	修订内容
1	2009-8-6	新制定。
2		
3		
4		

Torx Raised Countersunk Head Screws Refer to DIN 964

SIZE 尺寸:
Various

DWG NO. 图纸号: QE-FM-0139	CUSTOMER DWG NO. 客户图纸号: N/A	CONTRACT No. 合同号/ORDER No. 订单号: PFPL-FD090207	FINISH 表面处理: As required in order.	MATERIAL 材料: As Drawing
----------------------------	--------------------------------	--	---------------------------------------	----------------------------



DRAWN BY 制图:
Simon

DATE 日期:
2009-8-06

APPROVE BY 审核:

Sheet 页数:
1/1

UNITS 图纸单位:
mm