

SCALE 比例: N/A

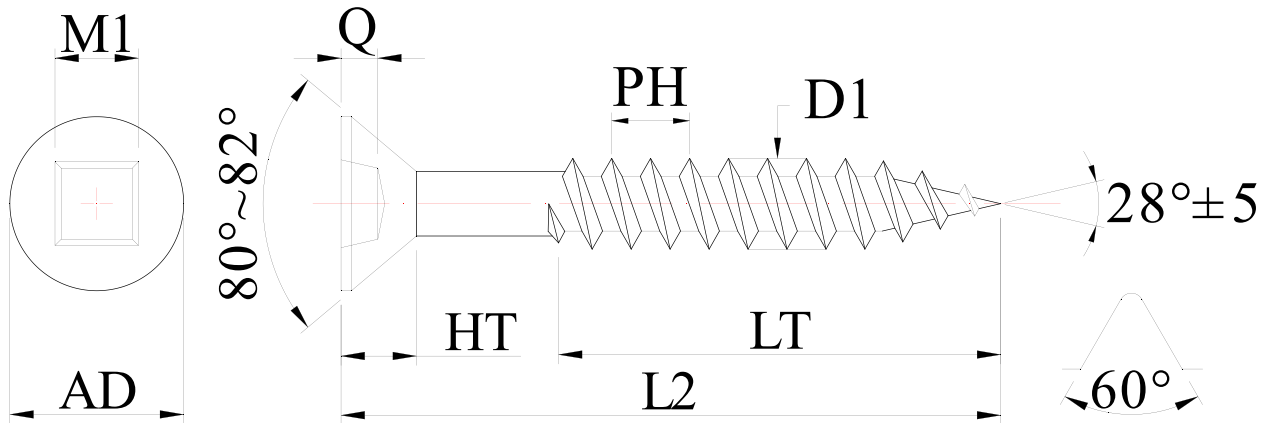

ROBERTSON □□□(□□)□ S

Specification	尺寸	AD	HT	M1	針號	Q	PH	D1		線徑
#5 - 20	Max	6.40	Ref	2.31	1	1.47	Ref	3.30		
	Min	5.58	1.91			1.22	2.54	3.20		
#6 - 18	Max	7.08	Ref	2.31	1	1.47	Ref	3.58		
	Min	6.19	2.11			1.22	2.82	3.46		
#7 - 16	Max	7.74	Ref	2.31	1	1.47	Ref	4.01		
	Min	6.80	2.31			1.22	3.18	3.86		
#8 - 15	Max	8.43	Ref	2.84	2	2.03	Ref	4.27		
	Min	7.41	2.54			1.78	3.38	4.12		
#10 - 13	Max	9.78	Ref	2.84	2	2.03	Ref	4.92		
	Min	8.63	2.95			1.78	4.24	4.78		
#12 - 11	Max	11.12	Ref	3.38	3	2.41	Ref	5.61		
	Min	9.88	3.35			2.03	4.62	5.46		

公稱長度 L2 Nominal Length	長度公差值 Tolerance	牙長(LT) Thread Length
Up to (□) 1-1/2(□)	±0.76mm	Full Thread(□□)
Over(□□)1-1/2□	±1.27mm	2/3 Thread

- Materials(□□)□C1022
- Thread Type(□□)□2A(TWINFAST THREAD)
- Case Hardness(□□□□)□HV450-720b
- Core Hardness(□□□□)□HV270-420b
- Torque(□□□□)□

#5: 2.02 Nm Min□ #6: 2.71 Nm Min□  
 #8: 4.41 Nm Min□ #10: 5.42 Nm Min□  
 #12: 9.38 Nm Min□

Square Drive (Robertson) Csk (Single) Head Hardened  
Twin Thread Woodscrews

SIZE 尺寸:  
Various

DWG NO. 图纸号: CUSTOMER DWG NO. 客户图纸号: CONTRACT No. 合同号/ORDER No. 订单号: FINISH 表面处理: BZP MATERIAL 材料: C1022



DRAWN BY 制图:

APPROVE BY 审核:

DATE 日期:  
2009.06.03

UNITS 图纸单位:  
mm

Sheet 页数:  
1/1